

GN19-12(C)Indoor AC High Voltage Disconnect Switch

Summary

GN19-12(C) indoor HV disconnect switch applies to power system of rated voltage below 12kV,AC 50/60Hz. It is equipped with CS6-1 manual-operating mechanism and is used to break and make circuit under no-load. There are additional pollution type, high-altitude type and electrified display.

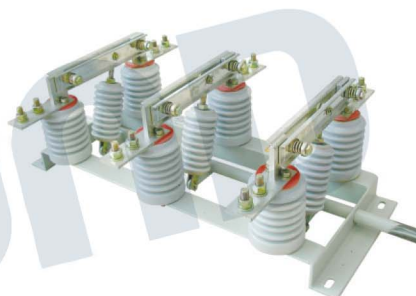

Ambient condition

1. Altitude: $\leq 1000\text{m}$;
2. Ambient temperature: $-25^{\circ}\text{C}\sim+40^{\circ}\text{C}$;
3. Relative humidity: daily average $\leq 95\%$, monthly average $\leq 90\%$;
4. Earthquake intensity: ≤ 8 degree;
5. Applicable occasions should free from inflammables, explosives, corrosives and severe vibration.

Model

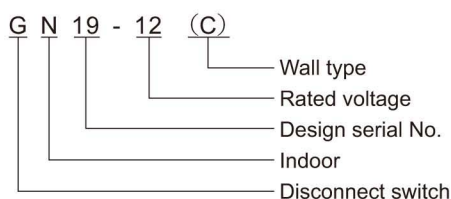

Product feature

1. Scientific design and simple structure.
2. Large clearance between gaps.
3. Small operating power and steady performance.

Technical specification

Model	Rated voltage (kV)	Rated current (A)	Rated short-time withstand current(kA/4s)	Rated peak withstand current(kA)
GN19-12/400-12.5	12	400	12.5	31.5
GN19-12/630-20	12	630	20	50
GN19-12/1000-31.5	12	1000	31.5	80
GN19-12/1250-31.5	12	1250	31.5	80
GN19-12C/400-12.5	12	400	12.5	31.5
GN19-12C/630-20	12	630	20	50
GN19-12C/1000-31.5	12	1000	31.5	80
GN19-12C/1250-31.5	12	1250	31.5	80

Outline dimension

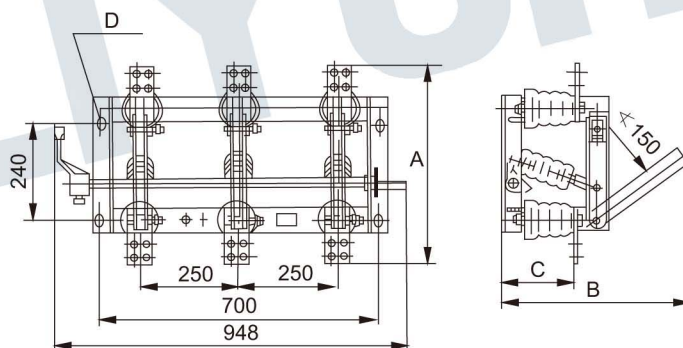

Diagram 1 GN19-12

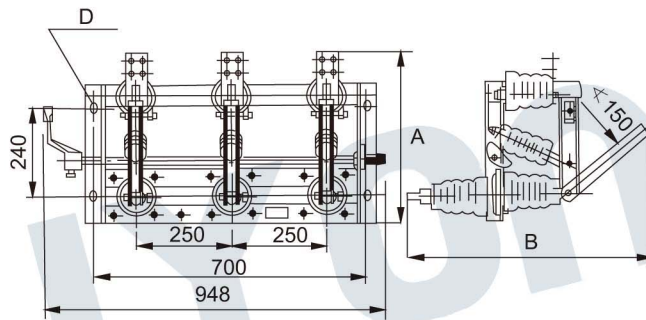
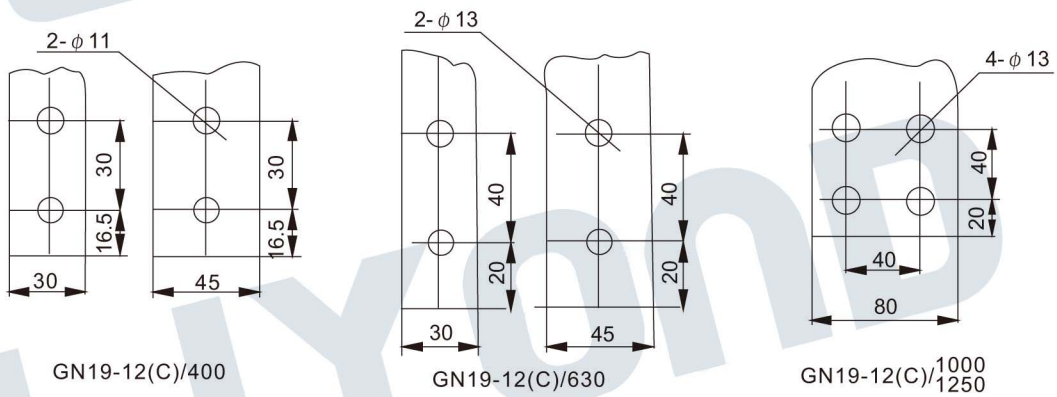

Diagram 2 GN19-12C



Model	A	B	C	D
GN19-12/400	450	446	185	4-14×24
GN19-12/630	470	446	185	
GN19-12/1000/1250	510	500	196	4-18×28
GN19-12C/400	420	690	185	4-14×24
GN19-12C/630	430	690	185	
GN19-12C/1000/1250	470	745	196	4-18×28